

Swivel Clamp Connector Joints

Aluminum / Stainless Steel

SPECIFICATION

Identification no.

No. **2**: With 2 stainless steel socket cap screws DIN 912

Aluminum

- Powder coated
Black, RAL 9005, textured finish **SW**
- Plain, matte shot-blasted **BL**

Stainless steel AISI CF-8 **NI**

Matte shot-blasted

Socket cap screws DIN 912

Stainless steel AISI 304

Hex nuts DIN 985

Stainless steel AISI 304

Self-locking via polyamide ring



INFORMATION

Swivel clamp connector joints GN 281 are an assembly of the swivel clamp connectors GN 271 (see page 1847) and GN 275 (see page 1854).

The clamping bore is mechanically machined and designed for construction tubes GN 990 (see page 1902) or DIN 2391, DIN 2395 and DIN 2462.

At the screw location **z1**, the socket cap screw reduces the bore cross-section for clamping.

For clamping without tools, the socket cap screws can be replaced by the adjustable hand levers GN 911 (see page 1874) / GN 911.3 (see page 1875) listed in the table as accessory.

ACCESSORY

- Adjustable Hand Levers GN 911 (see page 1874) / GN 911.3 (see page 1875)

TECHNICAL INFORMATION

- Stainless Steel Characteristics (see page A26)

* Complete with

SW **BL**
RAL9005 Plain

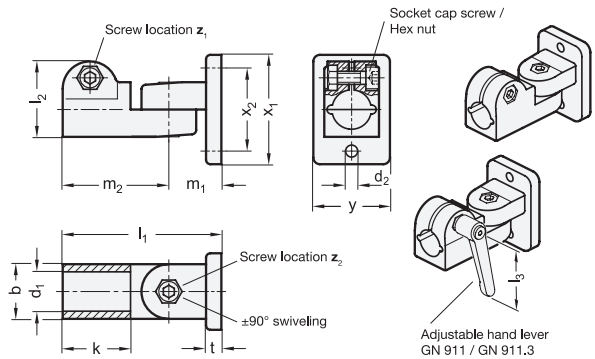

GN 281-AL

Description	d1 Bore	b	d2	k	l1	l2	m1	m2	t	x1	x2	y	z1 Screw location	z2 Screw location	Accessory Recom. hand lever GN 911 for z1 l3	Accessory Recom. hand lever GN 911 for z2 l3	⚖
GN 281-B12-2-*	B 12	25	5.5	31.5	72.5	34.5	24	48.5	7	50	38	35	M6-20	M6-20	63 -	45 63	126
GN 281-B14-2-*	B 14	25	5.5	31.5	72.5	34.5	24	48.5	7	50	38	35	M6-20	M6-20	45 63	45 63	122
GN 281-B15-2-*	B 15	25	5.5	31.5	72.5	34.5	24	48.5	7	50	38	35	M6-20	M6-20	45 63	45 63	120
GN 281-B16-2-*	B 16	25	5.5	31.5	72.5	34.5	24	48.5	7	50	38	35	M6-20	M6-20	45 63	45 63	116
GN 281-B18-2-*	B 18	25	5.5	31.5	72.5	34.5	24	48.5	7	50	38	35	M6-20	M6-20	45 63	45 63	114

Weight SW

GN 281-NI

STAINLESS STEEL

Description	d1 Bore	b	d2	k	l1	l2	m1	m2	t	x1	x2	y	z1 Screw location	z2 Screw location	Accessory Recom. hand lever GN 911.3 for z1 l3	Accessory Recom. hand lever GN 911.3 for z2 l3	⚖
GN 281-B12-2-NI	B 12	25	5.5	31.5	72.5	34.5	24	48.5	7	50	38	35	M6-20	M6-20	-	45 63	308
GN 281-B14-2-NI	B 14	25	5.5	31.5	72.5	34.5	24	48.5	7	50	38	35	M6-20	M6-20	-	45 63	301
GN 281-B15-2-NI	B 15	25	5.5	31.5	72.5	34.5	24	48.5	7	50	38	35	M6-20	M6-20	-	45 63	297
GN 281-B16-2-NI	B 16	25	5.5	31.5	72.5	34.5	24	48.5	7	50	38	35	M6-20	M6-20	-	45 63	291
GN 281-B18-2-NI	B 18	25	5.5	31.5	72.5	34.5	24	48.5	7	50	38	35	M6-20	M6-20	63 -	45 63	282
GN 281-B20-2-NI	B 20	25	5.5	31.5	72.5	34.5	24	48.5	7	50	38	35	M6-20	M6-20	45 63	45 63	276